

## Enduro Bag Mounts for the BMW /2 Series

30may2006

I have created a set of drawings for Enduro Bag mounts for the /2 series. They are based on one set of brackets loaned to me. I have tried to measure and reproduce the design accurately. I have built a set of brackets based on the design and they seem to fit well. I would appreciate any comments or corrections. There are two sizes of bags. I believe my bags are the larger size. I don't know if this design fits both.

### Caveats:

I am not a mechanical engineer so please excuse the simplicity of the drawings and realize they may not conform to any standard. I have photos of the original brackets to aid in visualizing the parts.

### Drawings:

Rather than detail all of the dimensions, I decided to create 1:1 drawings. The parts are simple enough, and the required tolerances large enough, to allow one to use the drawings as patterns, transferring coordinates with a snap-punch. Overall dimensions are shown to assure that the drawings have been printed truly to size. Be sure to set Page Scaling to 'None' and enable 'Auto-Rotate and Center' in the Print window. It appears to me that the parts were initially designed in inches, so I followed that lead. I show side views of the brackets and clamps to show how to bend them. The drawings have lines to show where the bends occur. The bends on the 'shelf' bracket are all the same way and are 90 degrees. The bar is split into two sheets so it can be printed on a standard letter size printer. I dimension the holes on the pre-bent drawing. Use the extra views to make the two bar bends. Don't forget to make two each of the shelf, bars, and side bracket parts and they must be mirror images! The small clamp brackets are different for each side (because of the tire pump), so only one set of those is needed. The clamps fit tight to the frame and fender. Just putting them on and off will scratch paint. One improvement to try would be to make the clamps slightly larger diameter so that a thin piece of rubber or the like could be placed between the clamp and frame.

### Materials:

The sheet metal is readily available at farm stores or a good hardware store. I used 16 gauge steel, which I believe is what the originals used. It is easily worked with standard shop tools.

The source for the bar is the same as above, but I was unable to find 3/16" x 7/8" bar stock. 3/4" is a bit too narrow to provide enough material around the oblong holes. I used 1" wide bar which will just fit above the muffler. The bar stock is fairly easy to work with as well.

The quarter-turn fasteners are a problem. I have not been able to locate the identical fasteners via internet. There are other choices that should work just as well. Dzus is probably the most well known and is available from several sources. One could always just bolt the bags in place, especially if it is intended to keep them mounted on the bike. Because of that, and the fact that I couldn't measure the rivet holes sizes and locations accurately, you may need to adjust the holes for the particular fasteners you use.

I used 4mm hardware for the clamp brackets. I don't know if the originals used that or #8 or #10 hardware.

### Machining, forming, and welding:

I have access to shop equipment such as a shear, brake, punch, drill press, and welder. Although the work could be done with hand tools, it may be worth while finding someone with access to a shop. The parts can be easily cut, bent, and punched over a few lunch hours. I actually milled the oblong holes in the bar stock, but they could be made by drilling a hole and filing to size.

To locate the bar on the 'shelf': The long part should butt up against the long bend in the shelf; the slight bend on the bar should point 'up' (bent side of 'shelf' points down); I measured 9" straight back from the center of the Druz hole to the center of the oblong hole nearest to the middle of the bar (see drawing).

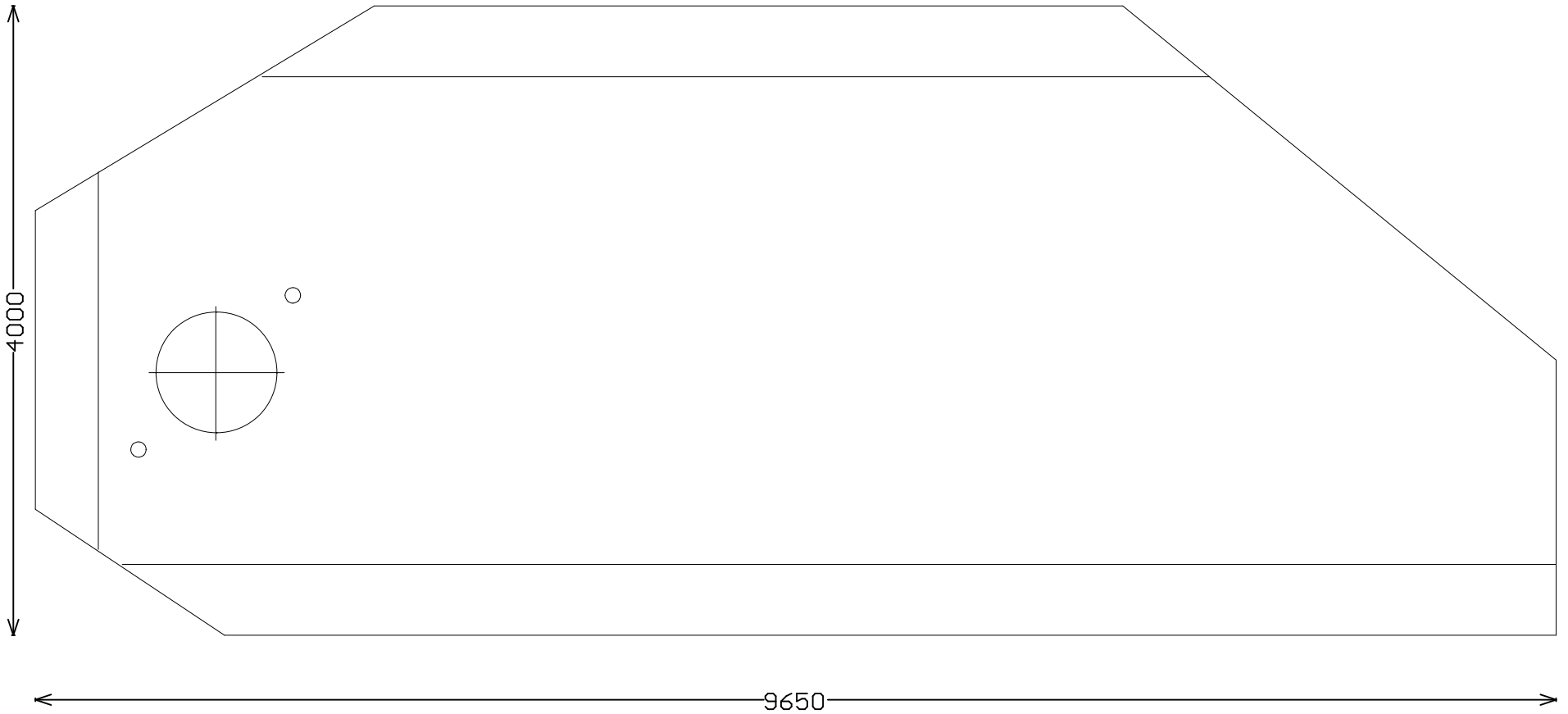

SHELF

26may2006

<FOLD EDGES DOWN FOR LEFT SIDE, UP FOR RIGHT SIDE>

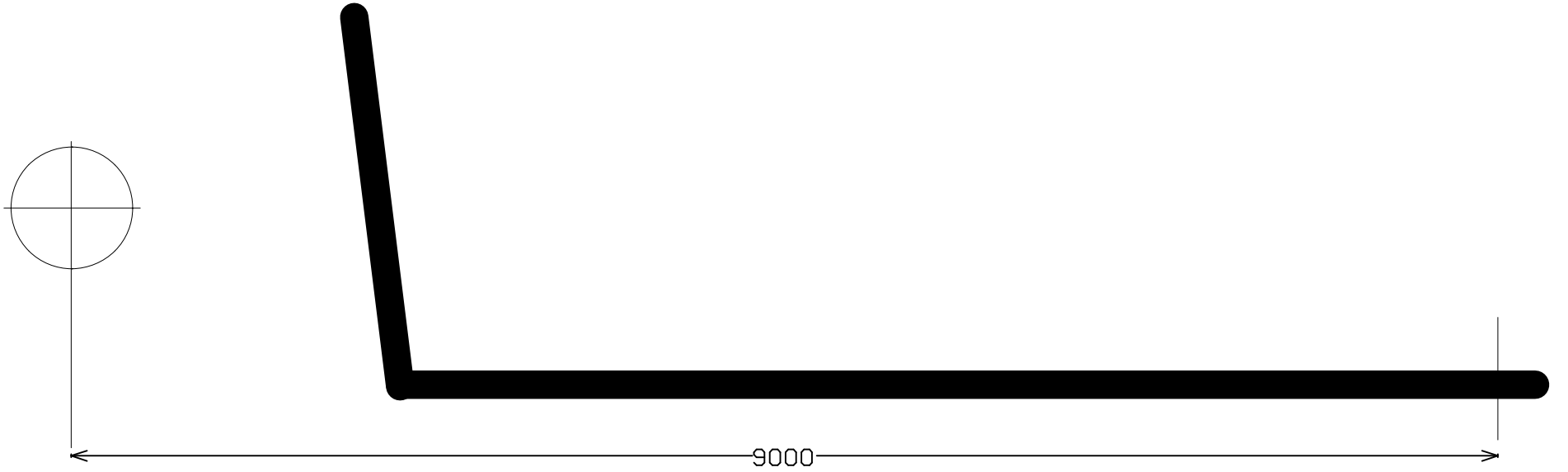

<DISTANCE FROM CENTER OF HOLE IN SHELF TO CENTER OF OBLONG HOLE IN BAR>

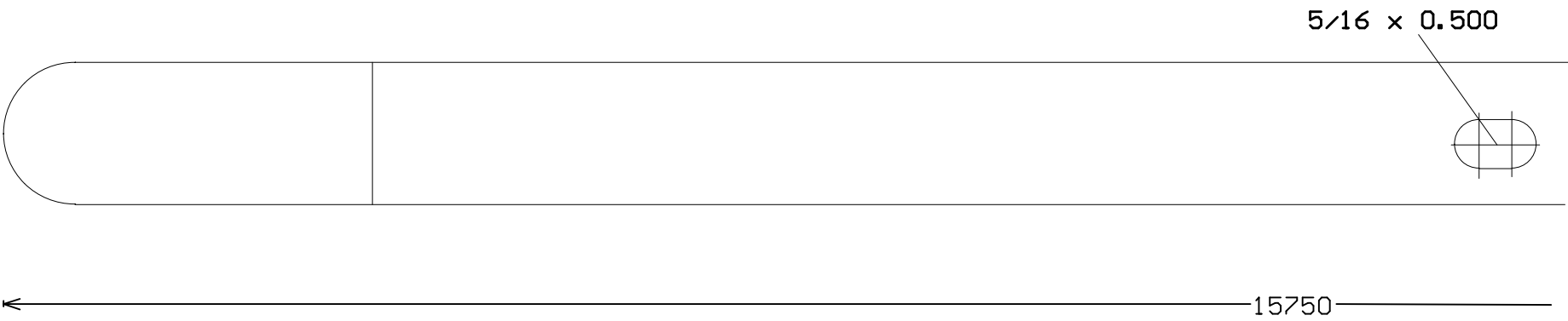

SHELF BAR

26may2006

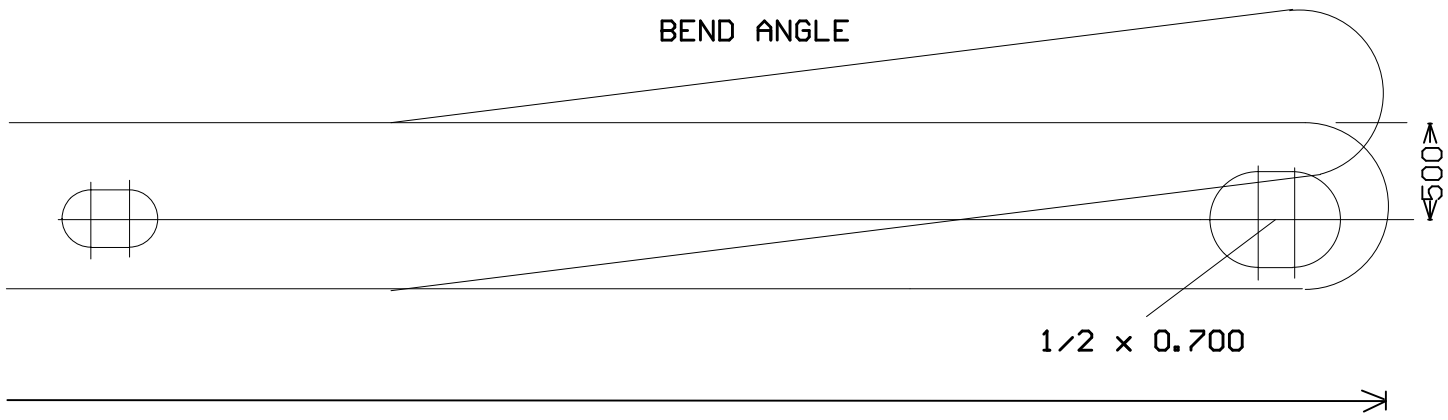

26may2006

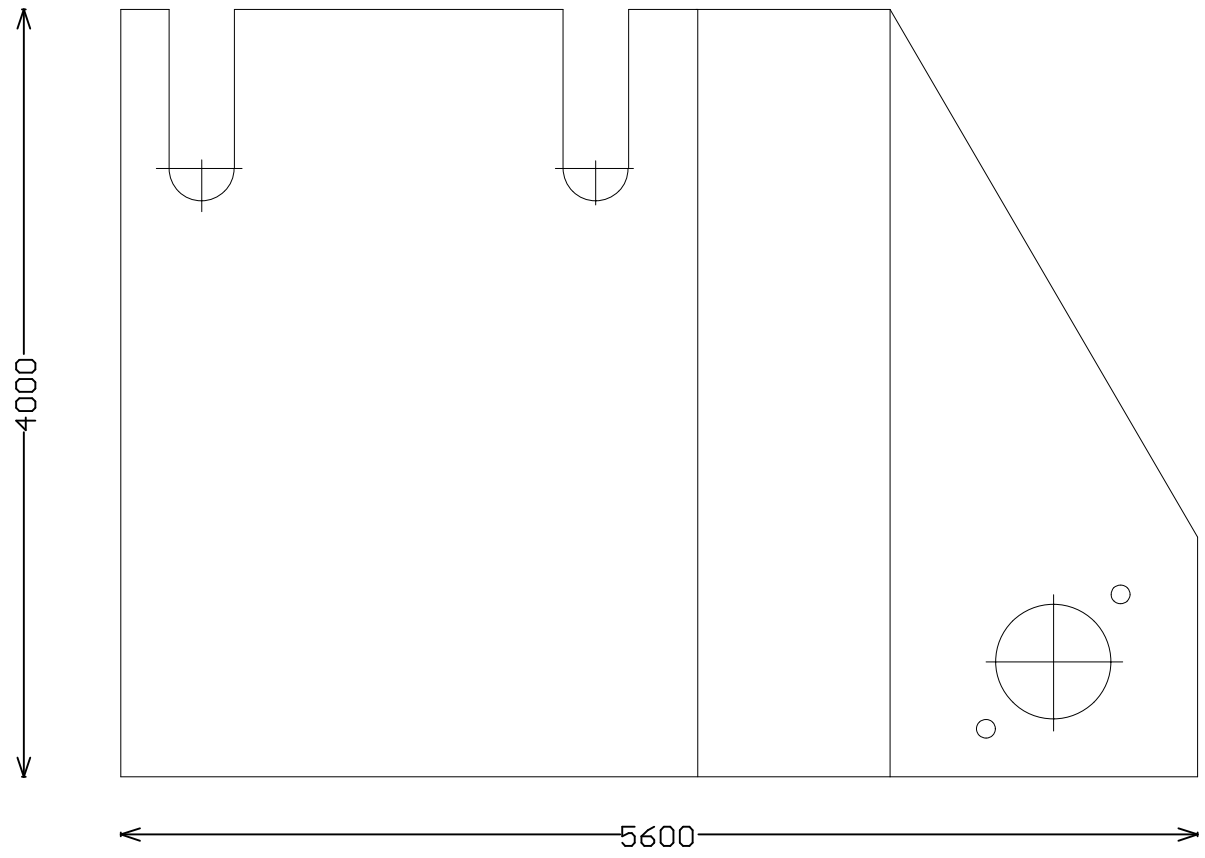

BRACKET (RIGHT SIDE SHOWN)  
(REVERSE FOR LEFT SIDE)

26may2006

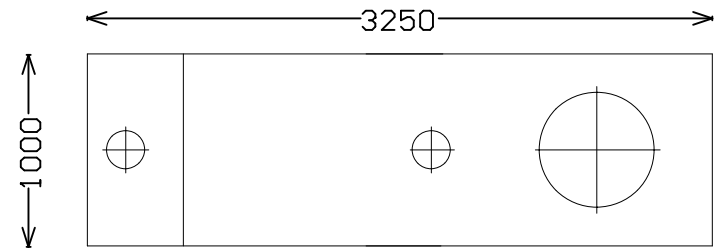
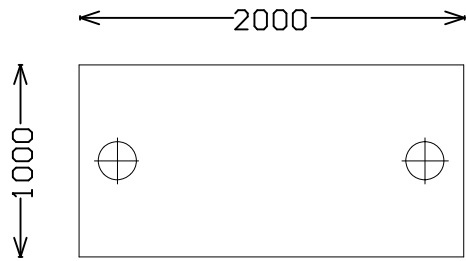

BOLT HOLES 0.200 DIA (8 PLCS)

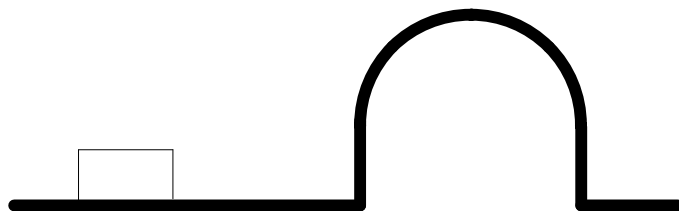
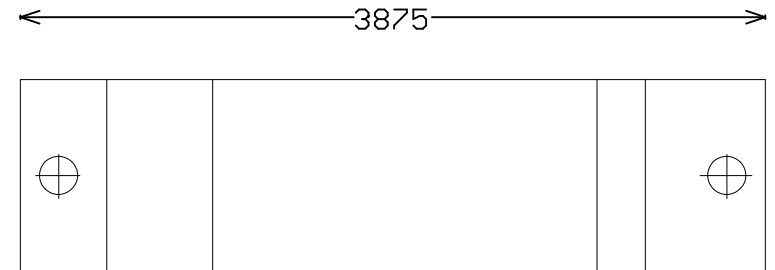
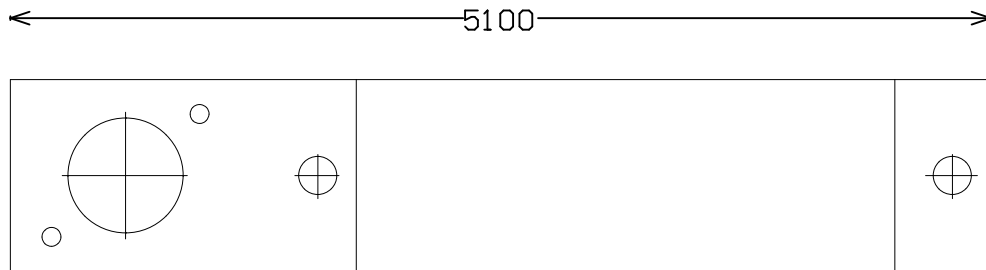

LEFT SIDE CLAMP

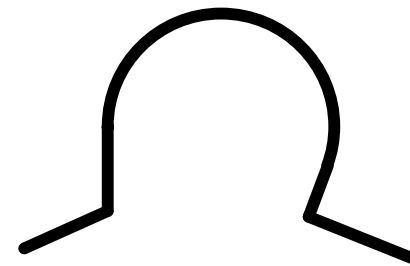

RIGHT SIDE CLAMP

26may2006

